

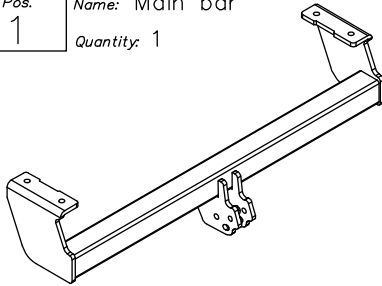





Towbar accessories:

Pos. 1	Name: Main bar Quantity: 1	Pos. 5	Name: Bolt 8,8 B Quantity: 4 Dim. : M12x1,25x35mm
		Pos. 6	Name: Nut 8 B Quantity: 2 Dim. : M12
			
Pos. 2	Name: Tow ball Quantity: 1	Pos. 7	Name: Plain washer Quantity: 6 Dim. : Ø 13 mm
			
Pos. 3	Name: Socket plate Quantity: 1	Pos. 8	Name: Spring washer Quantity: 6 Dim. : Ø 12,2 mm
			
Pos. 4	Name: Bolt 8,8 B Quantity: 2 Dim. : M12x75mm	Pos. 9	Name: Ball cover Quantity: 1
			

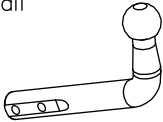

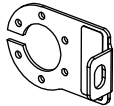
PPUH AUTO-HAK S.J.

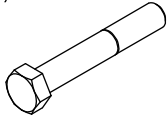
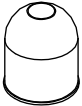
Produkcja Zaczepów Kulowych
Henryk & Zbigniew Nejman
76-200 SŁUPSK ul. Słoneczna 16K
tel/fax (059) 8-414-414; 8-414-413
E-mail: office@autohak.com.pl
www.autohak.com.pl

Towing hitch (without electrical set)

Class: **A50-X** Cat. no. **W08**

Designed for:

Manufacturer: **SUZUKI**

Model: **GRAND VITARA**

Type: **3/5 door**

produced since 09.1998 till 2005 and

Model: **GRAND VITARA XL-7**

produced since 2001 till 2006

Technical data:

D-value: 10,43 kN

maximum trailer weight: **1850 kg**

maximum vertical cup load: **80 kg**

Approval number acc. to regulations EKG/ONZ 55.01: E20-55R-01 1249

Foreword

This towbar is designed according to rules of safety traffic regulations. The towing hitch is a safety component and can be install only by qualified personnel. Any alteration or conversion of the towing hitch is prohibited and would lead to cancellation of design certification. Remove insulating compound and underseal from vehicle (if present) in the area of the matting surfaces of the towing hitch.

The vehicle manufacturer's specifications regarding trailer load and max. vertical cup load are decisive for driving whereat values for the towing hitch cannot be exceeded.

D-value formula:

$$\frac{\text{Max trailer weight [kg]} \times \text{Max vehicle weight [kg]}}{\text{Max trailer weight [kg]} + \text{Max vehicle weight [kg]}} \times \frac{9,81}{1000} = D \text{ [kN]}$$

FITTING INSTRUCTION

Clamp mark in acc. with		Cables joining
ISO	PN	
1	L	Left directional lights
2	+	Rear fog lights
3	31	Ground
4	R	Right directional lights
5	58R	Right side parking lights
6	54	Stoplights
7	58L	Left side parking lights

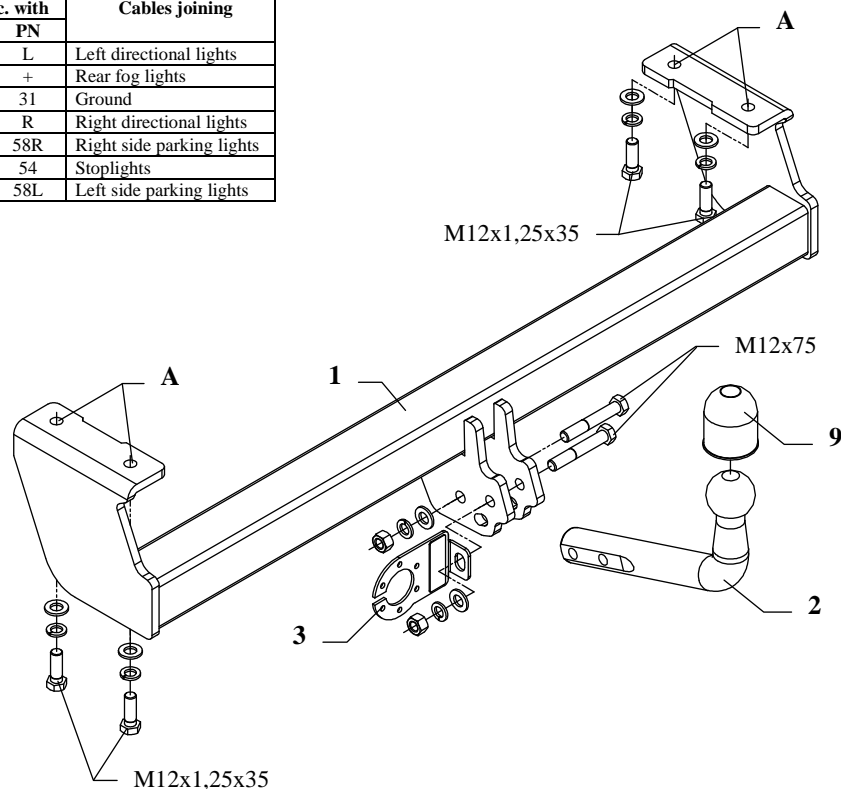

This towbar is designed to assembly in following cars:
SUZUKI GRAND VITARA, 3/5 door, produced since 09.1998 till 2005
 and **SUZUKI GRAND VITARA XL-7** produced since 2001 till 2006,
 catalogue no. **W08** and is prepared to tow trailers max total weight **1850 kg**
 and max vertical load **80 kg**.

From manufacturer

Thank you for buying our product. Their reliability has been confirmed in many tests. Reliability of towbar depends also on correct assembly and right operation. For this reasons we kindly ask to read carefully this instruction and apply to hints.

The towbar should be install in points described by a car producer.

The instruction of the assembly

1. Unscrew original towing eye, not used any more.
2. Put the main bar of the towbar (pos. 1) from below the car to chassis and through holes (pos. A) and existing in chassis threaded holes fix using bolts M12x1,25x35mm (pos. 5) from accessories.
3. To so prepared towbar fix tow-ball (pos. 2) with socket plate (pos. 3) using bolts M12x75mm (pos. 4) from accessories.
4. Tighten all bolts according to the torque shown in the table.
5. Connect electric wires of 7-poles socket according to the instruction of the car. (Recommend to make at authorized service station).
6. Complete paint layer damaged during installation.

Torque settings for nuts and bolts (8,8):

M6 - 11 Nm	M 8 - 25 Nm	M 10 - 50 Nm
M 12 - 87 Nm	M 14 - 138 Nm	M16 - 210 Nm

NOTE

After install the towbar you should get adequate note in registration book (at authorised service station).The car should be equipped with:

- Indicators
- Tow mirrors

After 1000km of exploitation check all bolts and nuts. The ball of towbar must be always kept clear and conserve with a grease.